

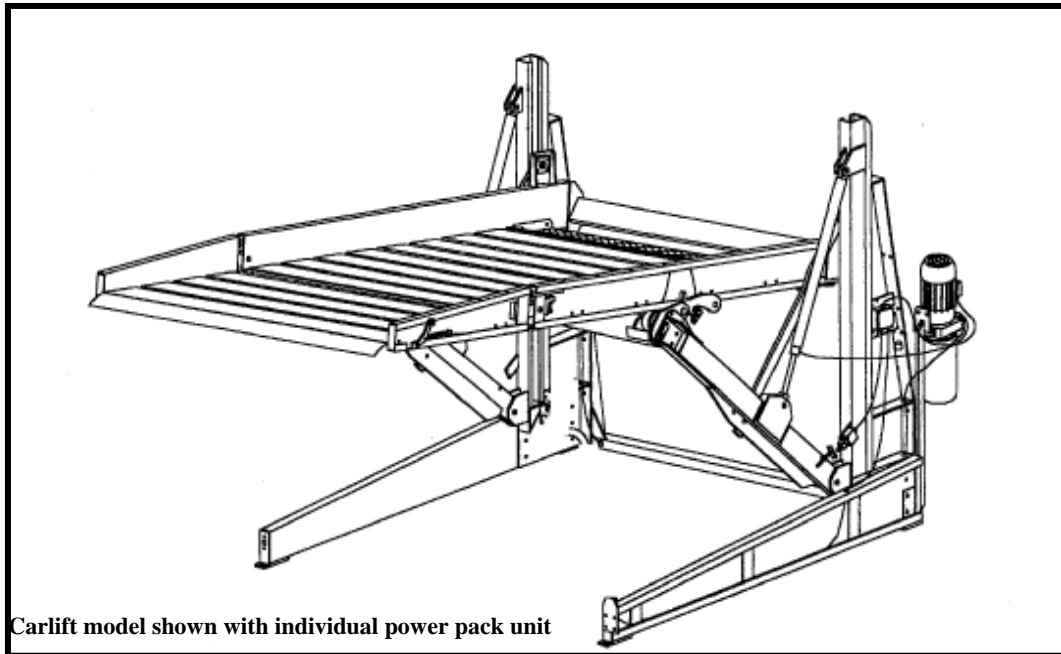

**HARDING
STEEL**

Harding Steel Car Lift



Carlift model shown with individual power pack unit

MODEL	A*	B*	C	D	E	F	G
Low-Narrow	4' 3"	5' 7"	7' 7"	12' 4"	11' 7"	6' 1"	8' 3"
Tall-Narrow	5' 7"	6' 11"	7' 7"	12' 4"	11' 7"	6' 1"	8' 3"
Low-Wide	4' 3"	5' 7"	8' 2"	12' 4"	11' 7"	6' 7"	8' 3"
Tall-Wide	5' 7"	6' 11"	8' 2"	12' 4"	11' 7"	6' 7"	8' 3"

Features

- 100% galvanized steel construction
- Commercial grade design and materials
- Dual hydraulic cylinders
- Self-standing, self-supporting unit
- Can be moved or relocated
- Individual or common hydraulic power pack
- Solid platform prevents dripping from upper level
- Accommodates most popular SUVs and minivans

Safety

- Individual operating switch per unit (optional key-lock)
- Automatic shut-off if operator releases the key-switch
- Steel-on steel locks hold the upper platform in place
- Manual lock release required to lower the unit

Power Requirements

- Common Power Packs: 30amp, 3phase, 220V
- Individual Power Pack: 110V, or 220V -single phase- 20amp

Dimensions

Typical ceiling heights

- Two Compacts 9'6"
- Two Full Size 10'0"
- One Full / One SUV 11'6"
- Two SUVs (6' height) 12'10"
- Two SUVs (6'3" height) 13'4"

Width (side-to-side dimension)

- 7'7" (narrow model)
- 8'2" (standard model)

Length

- 12'4" (total parking lift length)
- 11'7" (vehicle platform length)

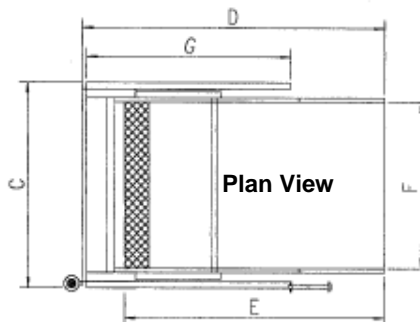

Plan View

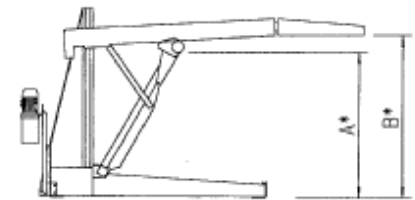

Cross Section



HARDING
STEEL

Harding Steel Low Model Car Lifts

Ideal for areas with less than 10' of vertical clearance

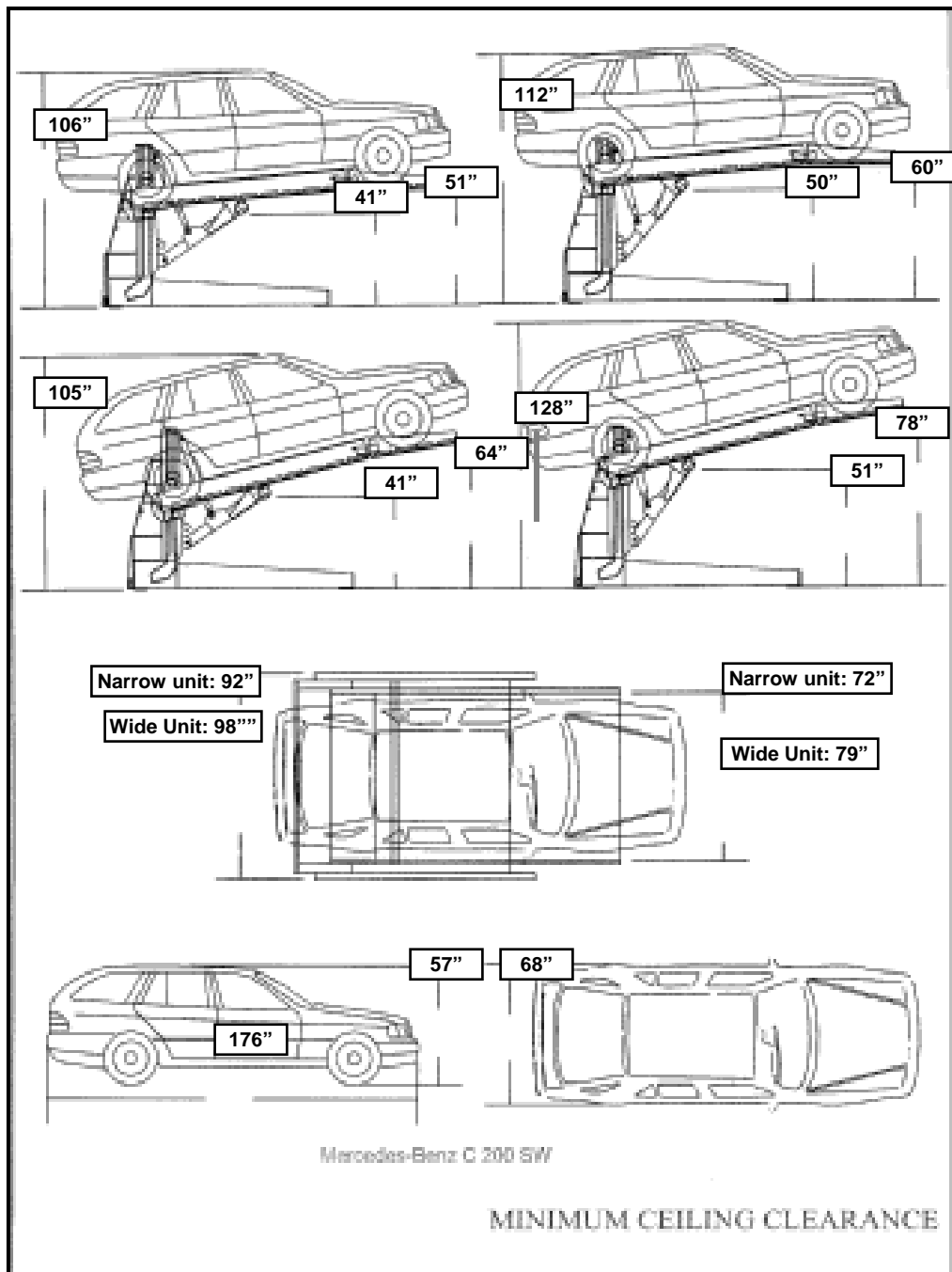

Dimensions are approximate and rounded to nearest whole inch



HARDING
STEEL

Harding Steel Tall Model Car Lifts

Ideal for areas with 10' or more of vertical clearance

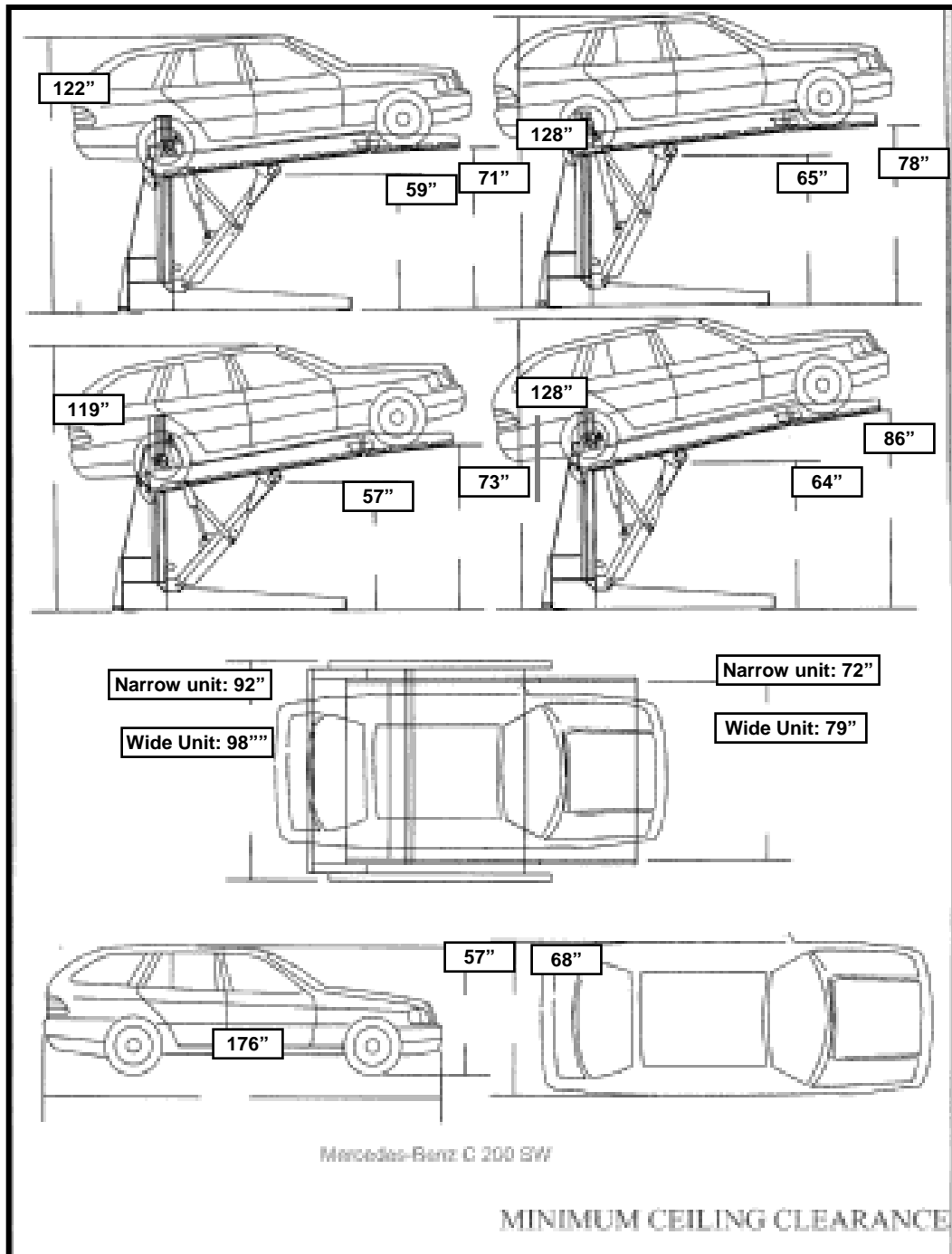

Dimensions are approximate and rounded to nearest whole inch



**HARDING
STEEL**

domestic bliss

HOT WHEELS

The garage, long considered a double-door blight on the suburban landscape, can be a great design opportunity by Brennan Kearney



DESIGNER TIPS

LIONEL MORRISON

- Use windows and skylights to introduce more natural light.
- Install an indoor faucet for easy car washing. Grade the floor so that water will flow down the driveway or into a central drain.
- Build an interior wall to divide parking and utility areas.

GRAY DAVIS

- Dress up the garage with decorative molding.
- Install heating and cooling systems to make it more comfortable.

MARTIN POIRIER

- Plant trees and other greenery to help disguise the driveway.
- Pave the driveway with something other than cement.

"Considering that the garage is often at least half the size of the rest of the house, it's shocking that we have forgotten to pay architectural attention to it for so long," says Kira Obolensky, author of *Garage: Reinventing the Place We Park* (Taunton). "At some point, people stopped thinking of their garages appropriately," says architect Bill Ingram. "They just globbed them onto their houses."

Ingram—whose designs include garages cleverly disguised as barns, complete with cupolas and weather vanes, and others that double as pool cabanas—treats the garage "as an outgrowth of the stable." Often, he has garage doors custom-made to mimic those you'd find on more picturesque outbuildings. In the Hamptons, architect Gray Davis created a Shingle-style garage that replicated the main house, down to the custom-milled shingles. Of course, a garage can be built to look like something else entirely. Plans for garages that look like fire, gas, or train stations are available from Jeff Heilman of JCH Designs, at vintagegarages.com.

Sometimes, all it takes to transform a garage is the addition of a thoughtful detail. For a client in Greenwich, Connecticut, who wanted a "romantic" garage, architect Anne Fairfax tucked a birdhouse into the eaves.

In his own small garage, landscape architect Martin Poirier installed a DuoPark lift system from Harding Steel (800-727-5325) that lets him make the most of the space by stacking two cars, one on top of the other. "To create a place for people, not cars," Poirier also planted a hedge on either side of his short driveway, and a patch of succulents and ivy down the middle, leaving only two narrow concrete strips.

Whatever changes you make to your own garage, we bet you won't have had this much fun parking since you were a teenager.



Harding Steel's DuoPark lift system makes room for two BMW M3s in Martin Poirier's tiny San Diego garage, above. In Birmingham, Bill Ingram's cottage-style garage suits the main house, far left.

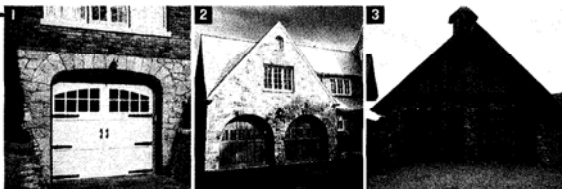

SOURCES: GREAT GARAGE DOORS

- Clopay Building Products: 800-225-6729. clopaydoor.com (1)
- Coffey Garage Doors: 800-400-1088. coffeydoors.com
- Designer Doors: 800-241-0525. designerdoorm.com (2)
- Gunnison Garage Doors: 970-641-2769. garagedoorsrus.com (3)
- Overhead Door Corporation: 800-929-3667. overheaddoor.com

TRIA GLOWN FOR SOUTHERN ACCENTS MAGAZINE; COURTESY OF MARTIN POIRIER; COURTESY OF GUNNISON GARAGE DOOR, INC. (3); COURTESY OF DESIGNER DOORS (2); COURTESY OF CLOPAY (1)